

GENERAL NOTES:

1. ENSURE ALL SHARP EDGES ARE GROUND SMOOTH.
2. PAINT AS PER CLIENT SPEC.
3. ENSURE ALL PART NUMBERS ARE CLEARLY MARKED ON COMPONENTS.
4. ALL WELDS TO CONFORM TO CLIENT STANDARDS.
5. ALL MATERIAL TO E MILD STEEL U.N.O.

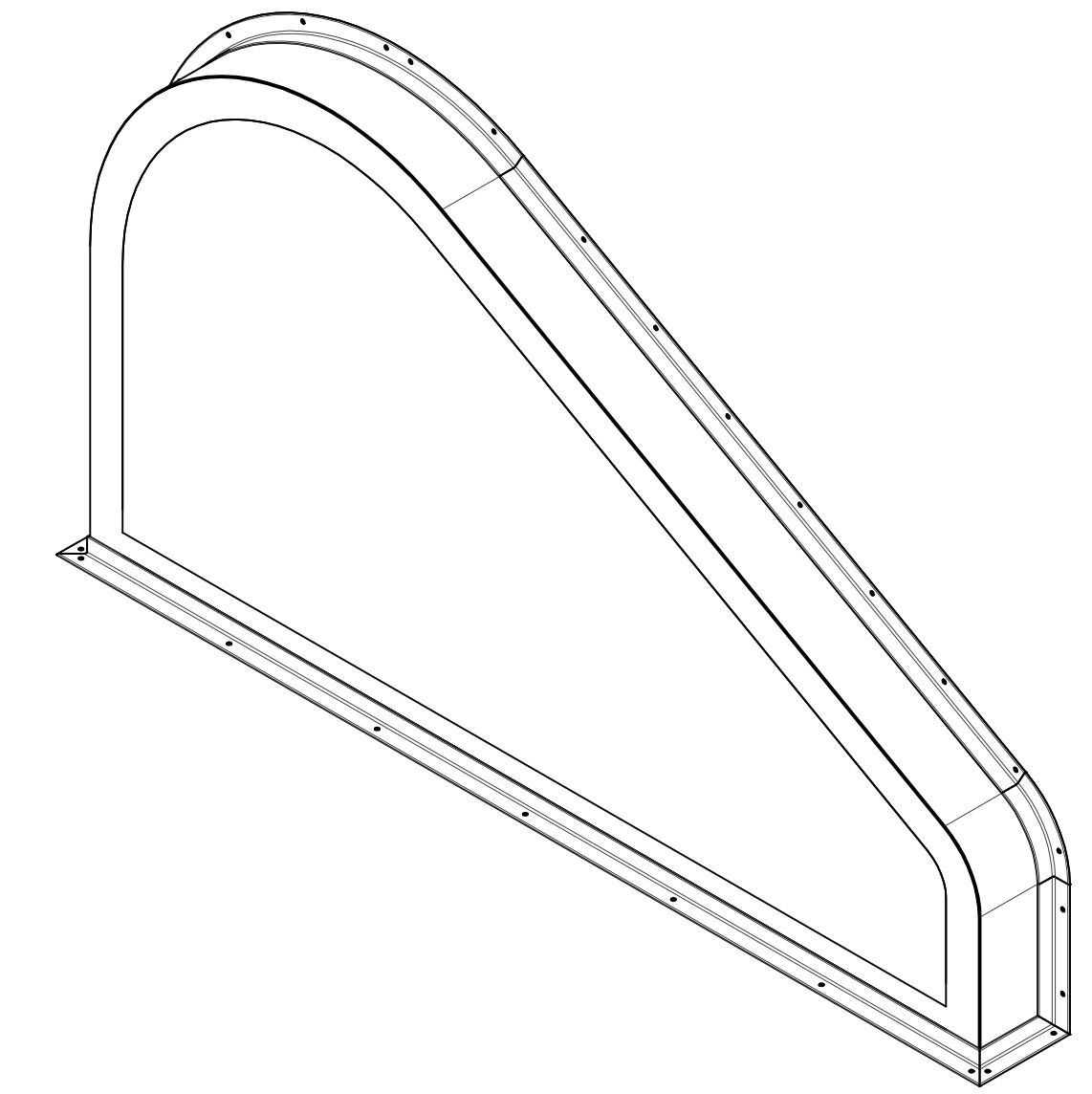

ISOMETRIC VIEW
SCALE 3/4"=1'-0"

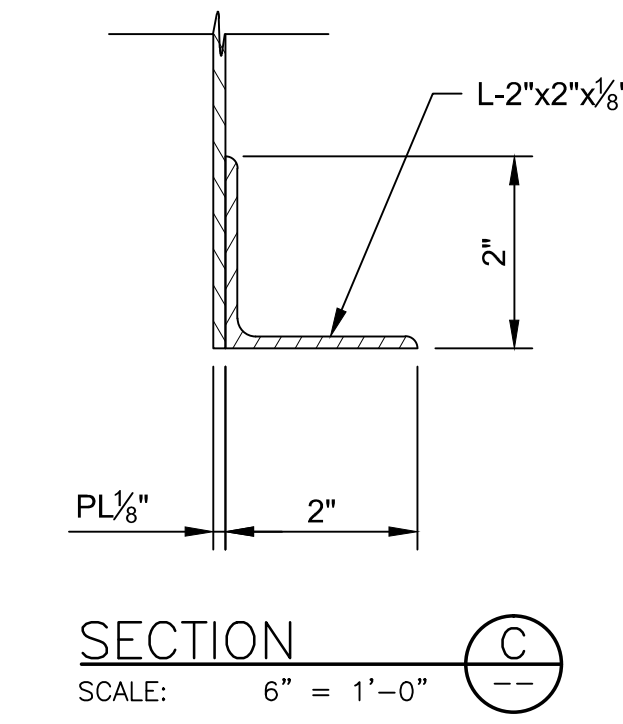
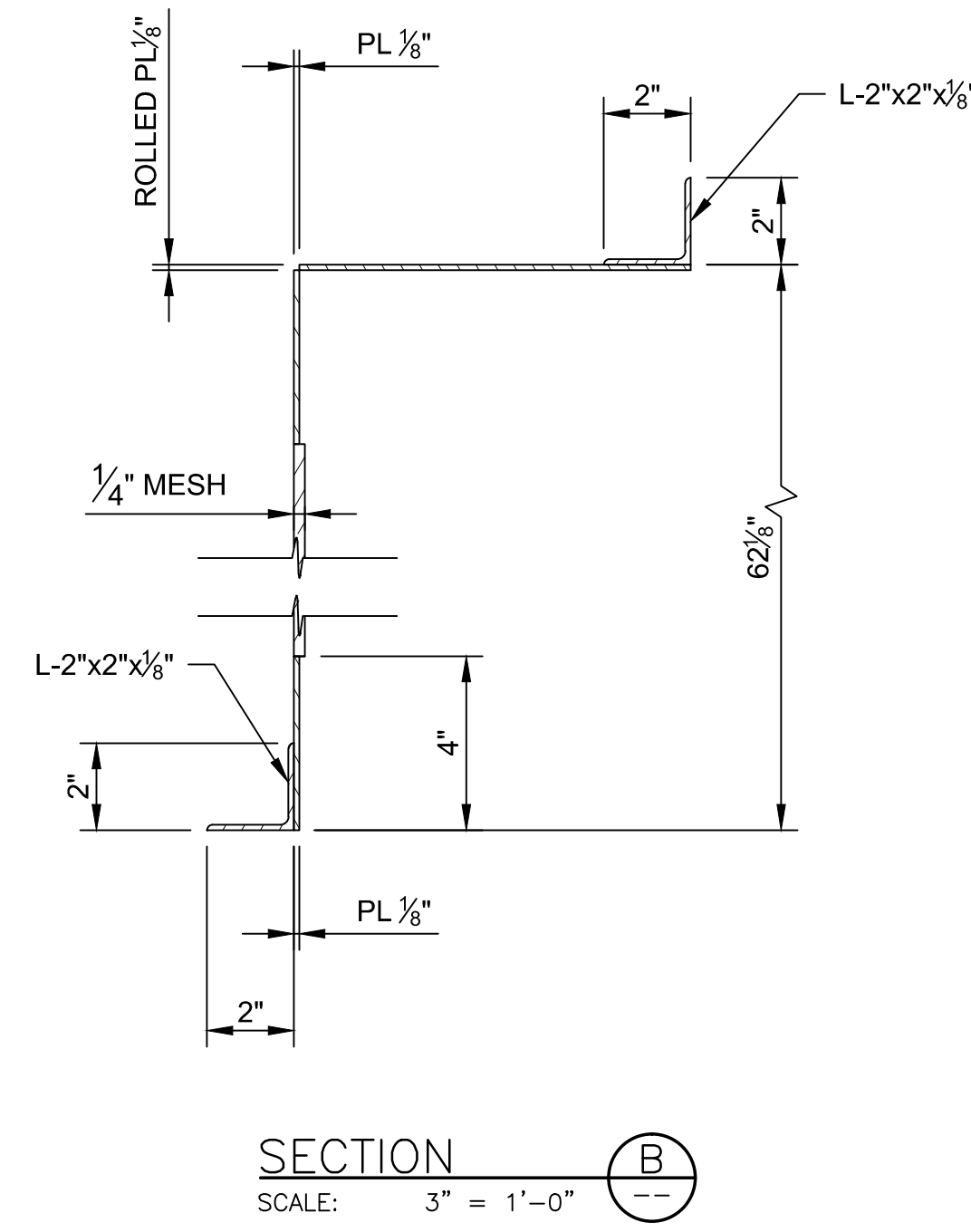
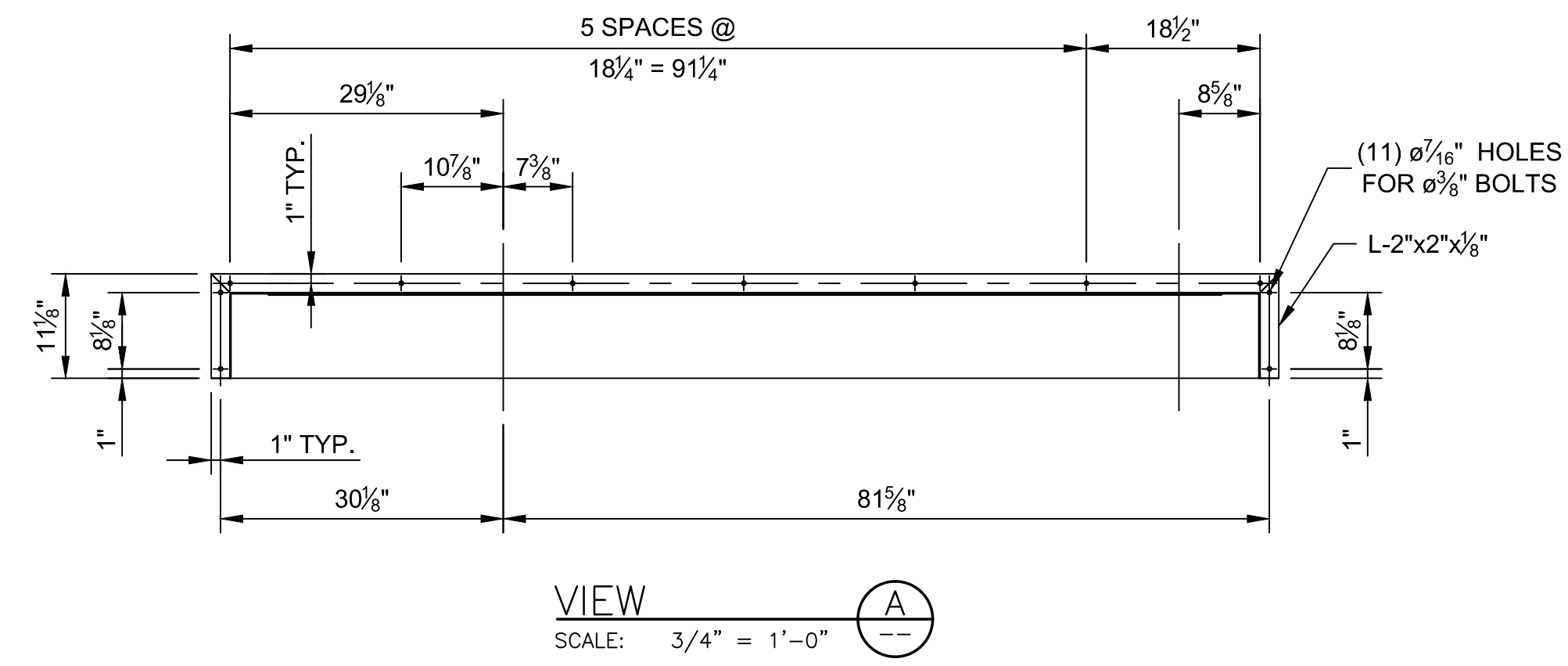
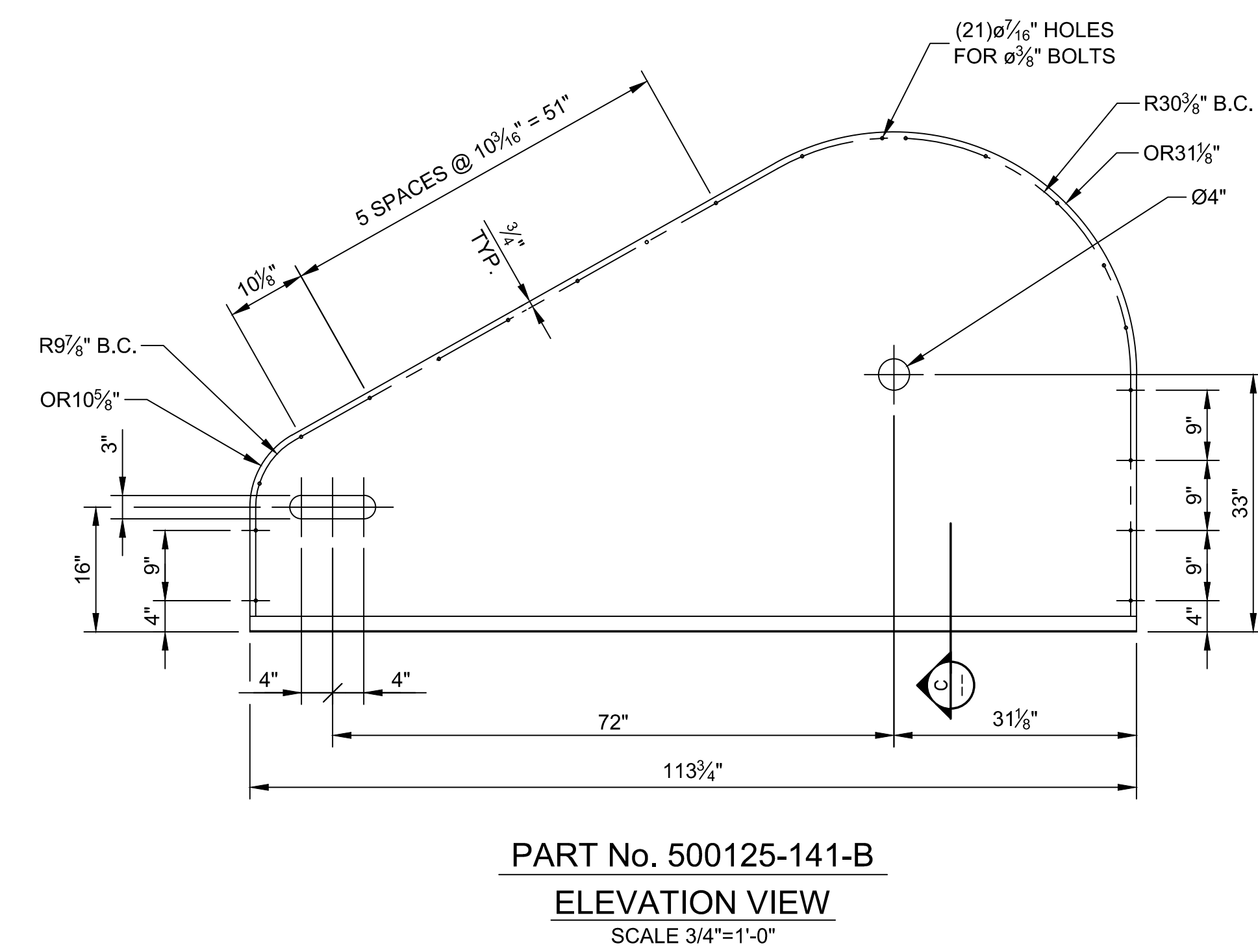
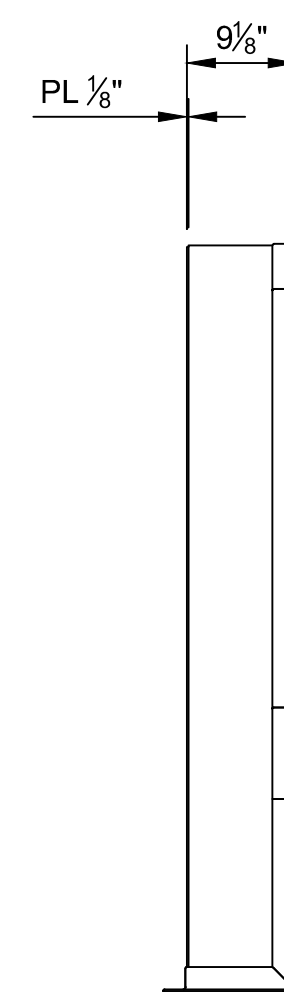
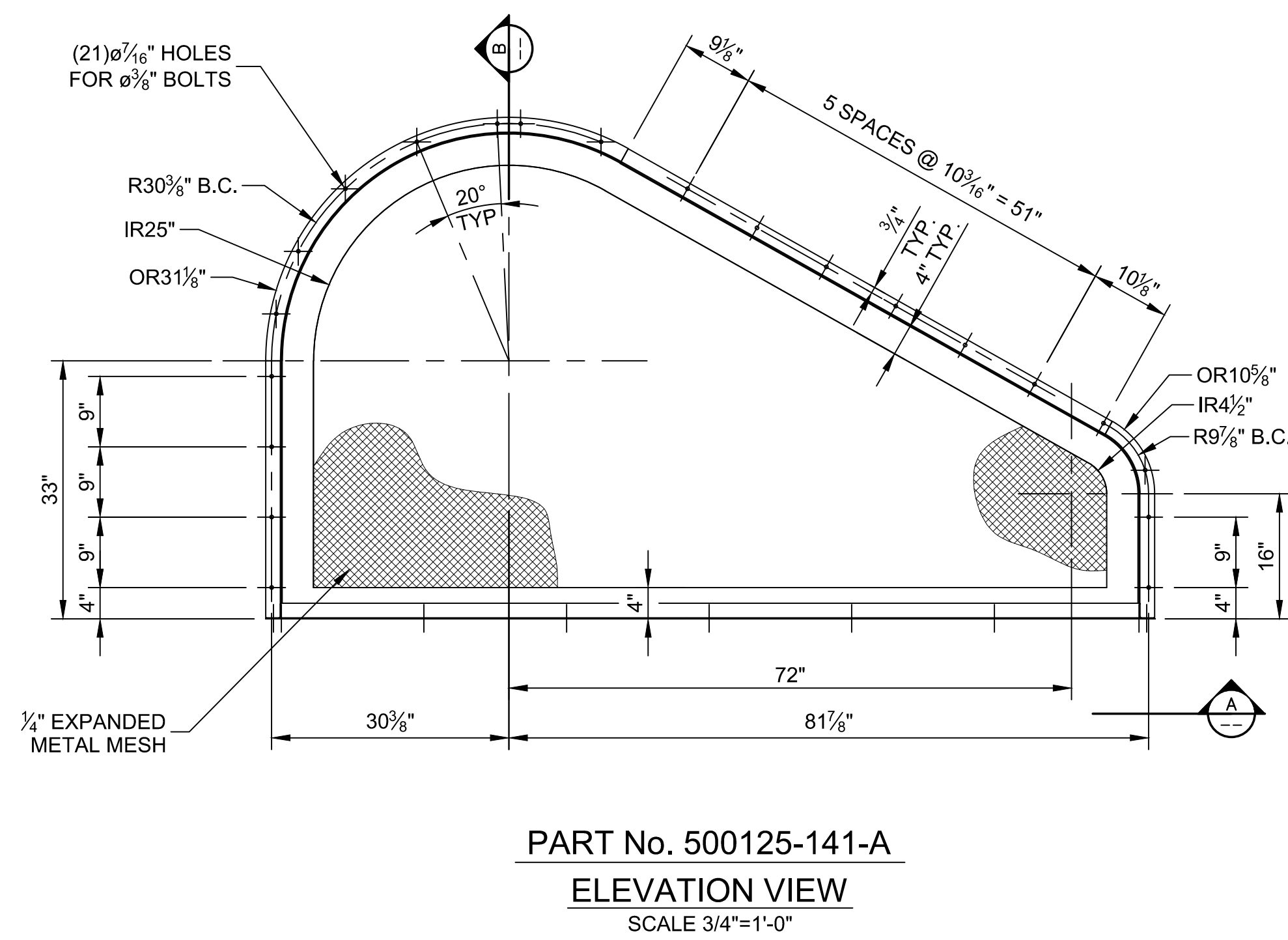

REVISIONS							
NO.	DESCRIPTION	BY	CHK	DATE	NO.	DESCRIPTION	BY

REVISIONS							
NO.	DESCRIPTION	BY	CHK	DATE	NO.	DESCRIPTION	BY

STAMP		

		PROJECT	
DWN. BY	DATE	TITLE	
TMB	28-FEB-2014	CRUSHER BELT GUARD SECTIONS AND DETAILS	
DESIGN BY	DATE	SCALE	JOB No.
EDC	28-FEB-2014	3/4"=1'-0"	125-02
CHK'D. BY	DATE	DWG. No.	500125-141
BDT	03-MAR-2014		